

4/2, 4/3 proportional directional valve, pilot operated, w/o electric position feedback without/with integrated electronics (OBE), with spool position indicator

RE 29117/08.13
Replaces: 06.08

1/20

Types 4WRZ(E)M and 4WRHM

Sizes 10 to 25
Component series 1X
Maximum operating pressure 350 bar
Maximum flow 870 l/min

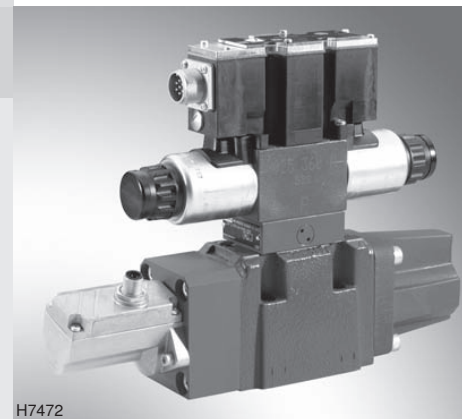

H7472

Table of contents

Contents	Page
Features	1
Ordering codes	2
Symbols (simplified)	3
Pilot oil supply	3
Function, section	4 ... 6
Technical data	7 ... 9
Electrical connection, block diagram	9 ... 11
Characteristic curves	12 ... 15
Dimensions	16 ... 19
Accessories	19
Safety instructions	20

Features

- Pilot operated, 2-stage proportional directional valves with integrated electronics (OBE) with type 4WRZE
- Spool position indicator
- In combination with a contact shut-off, the valve complies with the requirements for safety-related components of a control according to category 1, EN ISO 13849-1:2006
- Suitable for use in safety-related parts of controls according to category 4, EN ISO 13849-1:2006
- Control of flow direction and size
- Operation by means of proportional solenoids with central thread and detachable coil
- Subplate mounting, porting pattern according to ISO 4401
- Manual override, optional
- Spring-centered control spool

Information on available spare parts:
www.boschrexroth.com/spc

Ordering codes



Hydraulic actuation = H
 Electro-hydraulic actuation = Z
Only with WRZ:
 With external electronics = no code
 With integrated electronics = E
 Monitoring the switching position = M
 Size 10 = 10
 Size 16 = 16
 Size 25 = 25
 Size 32, see data sheet 29118

Control spool symbols

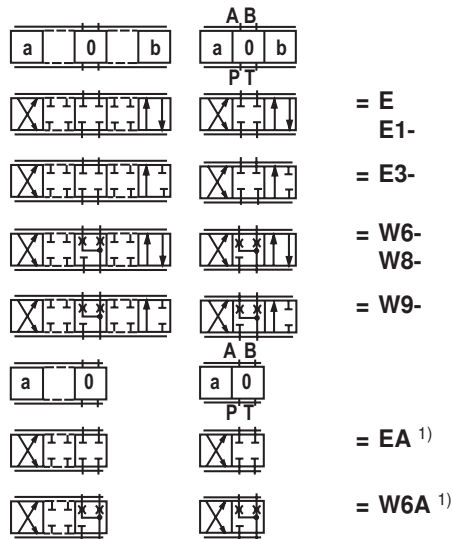

With symbols E1- and W8-:
 P → A: q_v B → T: $q_v/2$
 P → B: $q_v/2$ A → T: q_v

With symbols E3- and W9-:
 P → A: q_v B → T: Blocked
 P → B: $q_v/2$ A → T: q_v
 (differential circuit, piston top at port A)

Notice:
 With spools W6-, W8-, W9-, W6A, there is a connection from A → T and B → T with less than 2% of the respective nominal cross-section in switching position "0".

For further details, see the plain text

M = NBR seals
 V = FKM seals

no code = Without pressure reducing valve
 D3 ¹⁾ = With pressure reducing valve ZDR 6 DP0-4X/40YM-W80 (not adjustable)

Electronics interface for 4WRZEM:

A1 = Command value input ±10 V
 F1 = Command value input 4 to 20 mA

no code = For WRZM and WRHM

Electrical connection for WRZM:

K4 = Without mating connector with connector according to DIN EN 175301-803
 Mating connector – separate order, see page 19

for WRZEM:

K31 = Without mating connector with connector according to DIN EN 175201 804
 Mating connector – separate order, see page 19

Pilot oil supply and return

no code = External pilot oil supply, external pilot oil return
 E ¹⁾ = Internal pilot oil supply, external pilot oil return
 ET ¹⁾ = Internal pilot oil supply, internal pilot oil return
 T ¹⁾ = External pilot oil supply, internal pilot oil return

no code = Without manual override
 N9 ¹⁾ = With concealed manual override

Supply voltage of the electronics

G24 ¹⁾ = 24 V direct voltage (standard version)

6E ¹⁾ = Pilot control valve size 6, proportional solenoid with detachable coil

1X = Component series 10 to 19
 (10 to 19: Unchanged installation and connection dimensions)

Rated flow in l/min at valve pressure differential $\Delta p = 10$ bar

25 =	50 =	85 =		Size 10
100 =	125 =	150 =	180 =	Size 16
220 =	325 =			Size 25

¹⁾ Not applicable to 4WRH

Symbols (simplified)

With electro-hydraulic actuation and for external electronics

Type 4WRZM...

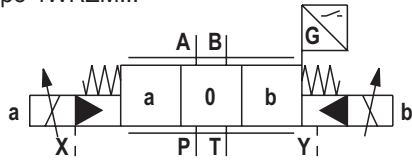

Pilot oil supply

X = external
Y = external

Type 4WRZM...A...

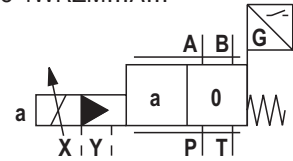

Type 4WRZM.../...ET...

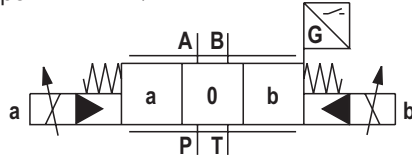

X = internal
Y = internal

Type 4WRZM...A.../...ET...

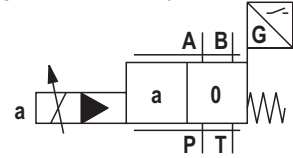

With electro-hydraulic actuation and integrated electronics

Type 4WRZEM...

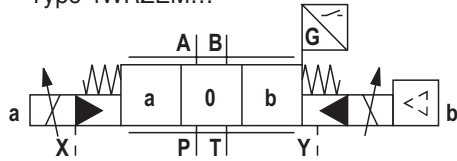

X = external
Y = external

Type 4WRZEM...A...

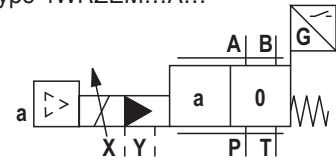

Type 4WRZEM.../...ET...

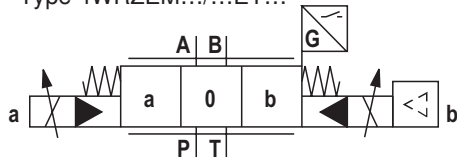

X = internal
Y = internal

Type 4WRZEM...A.../...ET...

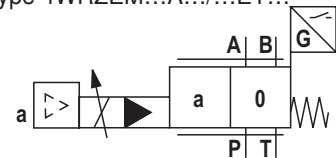

With hydraulic actuation

Type 4WRHM...

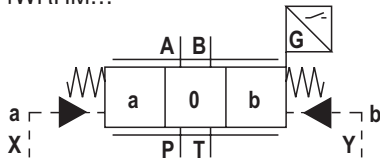

Type 4WRHM...A...

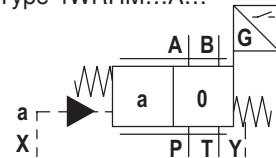

Pilot oil supply

Type 4WRZ(E)M... and type 4WRHM...

Extern pilot oil supply External pilot oil return

With this version, the pilot oil is supplied from a separate pilot circuit (externally).

The pilot oil return is not conducted into the T channel of the main valve, but is directed separately to the tank via port Y (externally).

Type 4WRZ(E)M...E...

Internal pilot oil supply External pilot oil return

With this version, the pilot oil is supplied from the P channel of the main valve (internally).

The pilot oil return is not conducted into the T channel of the main valve, but is directed separately to the tank via port Y (externally). Close port X in the subplate.

Type 4WRZ(E)M...ET...

Internal pilot oil supply Internal pilot oil return

With this version, the pilot oil is supplied from the P channel of the main valve (internally).

The pilot oil is returned directly to the T channel of the main valve (internally).

Close ports X and Y in the subplate.

Type 4WRZ(E)M...T...

External pilot oil supply Internal pilot oil return

With this version, the pilot oil is supplied from a separate pilot circuit (externally).

The pilot oil is returned directly to the T channel of the main valve (internally).

Close port Y in the subplate.

Function, section

Pilot control valve for 4WRZ(E)M... (type 3DREP(E)6...)

The pilot control valve is a 3-way pressure reducing valve that is actuated by a proportional solenoid. It converts an electrical input signal into a proportional pressure output signal.

The proportional solenoids are controllable, wet-pin DC solenoids with a central thread and a detachable coil. The solenoids can either be controlled by external electronics (type 4WRZM...) or by integrated electronics (type 4WRZEM...).

Set-up:

The pilot control valve basically consists of:

- Housing (1)
- Control spool (2) with pressure measuring spool (3 and 4)
- Solenoids (5 and 6) with central thread
- Optionally with Integrated electronics (7)

Function:

The pressure in A or B is set by means of the proportional solenoids. The amount of the pressure depends on the current.

With de-energized solenoids (5, 6), the control spool (2) is held in the central position by means of the pressure springs (8). Ports A and B are connected with T so that the hydraulic fluid can flow to the tank without obstructions.

By energizing a proportional solenoid, e.g. solenoid "a" (5), the pressure measuring spool (3) and with it the control spool (2) are moved to the right. This opens the connection from P to B and A to T via orifice-type cross-sections with progressive flow characteristic. With the surface of the pressure measuring spool (4) the pressure that builds up in channel B acts on the control spool and against the solenoid force. The pressure measuring spool (4) is supported by solenoid "b". If the pressure exceeds the value set at solenoid "a", the control spool (2) is pushed back against the solenoid force and connects B with T until the set pressure is reached again. The pressure is proportional to the solenoid current.

When the solenoid is switched off, the control spool (2) is returned into the central position by the compression springs (8).

Type 3DREPE 6...

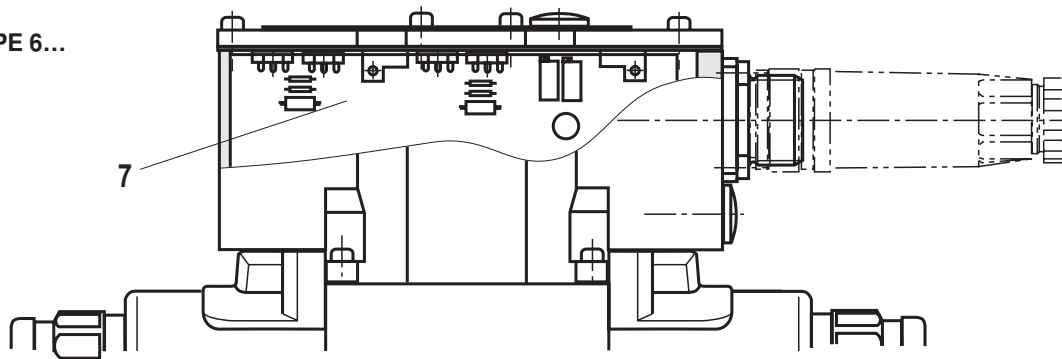

Type 3DREP 6...

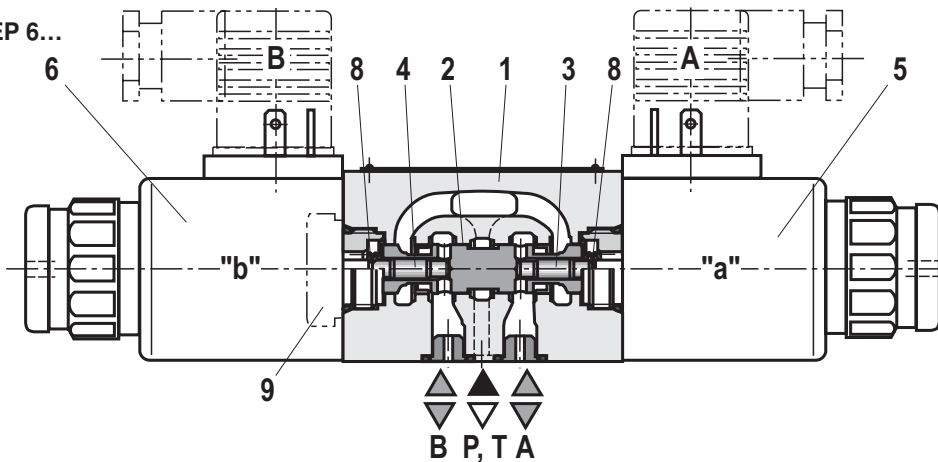

Pilot control valve for 4WRZ(E)M...A... with two switching positions (type 3DREP(E)6...B...)

The operation of this valve version basically corresponds to the valve with 3 switching positions. However, this 2 spool position valve is only equipped with solenoid "a" (5).

In the place of the second proportional solenoid there is a plug screw (9).

Function, section

Electro-hydraulically actuated proportional directional valves Type 4WRZ(E)M...

Valves of type 4WRZ(E)M... are pilot operated proportional directional valves with spool position indicator.

They control the flow direction and size.

They are actuated by the proportional solenoids of the pilot control valve (see description on page 4).

Set-up:

The valve basically consists of:

- Pilot control valve (10) with proportional solenoids (5) and (6)
- Main valve (11) with main control spool (12), valve spring (13) and position indicator (14)

Function:

- With de-energized solenoids (5) and (6), the main control spool (12) is held in the central position by the valve spring (13).
- By energizing a proportional solenoid, e.g. solenoid "b" (6) the control spool (2) is moved to the right. Pilot oil enters the pressure chamber (15). The generated pressure moves the main control spool (12) proportionally to the electric input signal against the valve spring (13). This opens the connection from P to A and B to T via orifice-type cross-sections with progressive flow characteristic.
- Depending on the type, pilot oil is internally supplied to the pilot control valve via port P or externally via port X.
- When the solenoid (6) is switched off, the control spool (2) is returned into the central position by the compression springs (8). This unloads the pressure chamber (15) towards the tank and the main control spool (12) is returned to the central position by the valve spring (13).
- Depending on the type, the pilot oil is returned internally from the pilot control valve to the tank via port T or externally via port Y.
- An optional manual override (16 and 17) allows the control spool (2) and with it the main control spool (12) to be moved.

Inadvertent activation of the manual override may result in uncontrollable machine movements!

Notice:

The tank line must not be allowed to run empty. If this is possible due to the installation conditions, install a preload valve (with a preload pressure of approx. 2 bar).

Spool position indicator:

The switching positions of the main control spool are detected by the inductive position switch (14) and displayed via two switching outputs with a preset logic. If the preset switching points are exceeded, the deviation from the zero position is displayed within the control spool overlap (see page 12).

The switching signals can be used in a superior control for monitoring purposes.

The electrical connection is implemented separately via a 4-pole connector M12x1 with two pins for signal output and two pins for voltage supply.

Area of application:

The valve may be used in machines with high safety requirements, e.g. hydraulic press control systems.

In combination with a contact shut-off, the valve complies with the requirements for safety-related components of a control according to category 1, EN ISO 13849-1:2006. The "emergency stop" command or an error detected by the machine control has to result in cutting the valve supply voltage.

For the valve design the basic and well-tried safety principles according to ISO 13849-2:2003, tables C1 and C2 were used.

The valves are suitable for use in safety-related parts of controls according to category 4, EN ISO 13849-1:2006. This requires the entire control to meet the requirements of category 4, EN ISO 13849-1:2006 as well as the respective requirements of the applicable standards.

Please note chapter "Safety instructions" on page 20!

Function, section (continued)

Type 4WRZEM10...-1X...

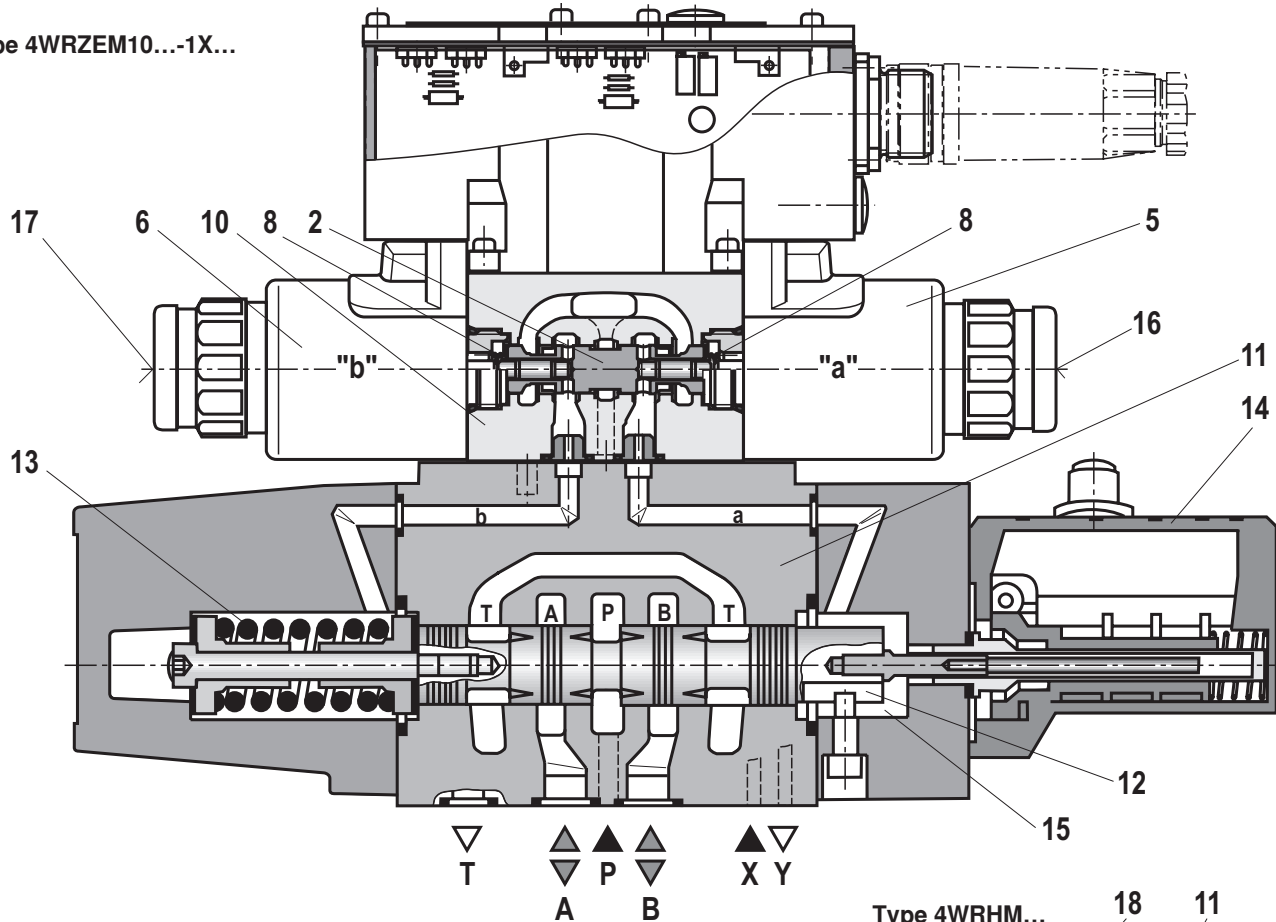

Hydraulically actuated proportional directional valves

Type 4WRHM...

Valves of type 4WRHM... are pilot operated proportional directional valves with spool position indicator. They control the flow direction and size. Actuation is carried out hydraulically via external pressure control valves.

Set-up:

The valve basically consists of:

- Main valve (11) with main control spool (12), valve spring (13) and position switch (14)
- Diversion plate (18)

Function:

- The diversion plate (18) connects control channel (a) that leads to the pressure chamber (15) with port Y and control channel (b) with port X.
- When ports X and Y are pressurized, the main control spool (12) can be moved proportionally in both directions.
- At a pressure of approx. 5 bar the connection from P-A/ B-T and/or P-B/A-T is opened. At 25 bar the maximum opening cross-section is reached.

The pilot pressure at X and Y must not exceed 25 bar.

Area of application:

The valve may be used in machines with high safety requirements, e.g. hydraulic press control systems.

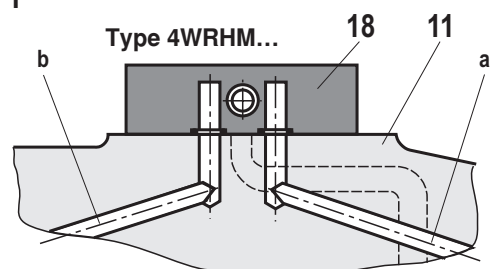

The valve corresponds to the requirements for safety-related control parts according to category 1, EN ISO 13849-1:2006. The "emergency stop" command or an error detected by the machine control has to result in unloading the control ports X and Y.

For the valve design the basic and well-tried safety principles according to ISO 13849-2:2003, tables C1 and C2 were used.

The valves are suitable for use in safety-related parts of controls according to category 4, EN ISO 13849-1:2006. This requires the entire control to meet the requirements of category 4, EN ISO 13849-1:2006 as well as the respective requirements of the applicable standards.

Please note chapter "Safety instructions" on page 20!

Technical data (for applications outside these parameters, please consult us!)**general**

Valve type		4WRZM	4WRZEM	4WRHM
Installation position		Any, preferably horizontal (for commissioning information, see data sheet 07800)		
Storage temperature range	°C	-20 to +80		
Ambient temperature range	Size 10/16/25 °C	-20 to +50	-20 to +50	
Weight	Size 10 kg	8.2	9.0	6.5
	Size 16 kg	13.0	13.7	10.1
	Size 25 kg	20.2	20.9	18.4
	With "D3" kg	+0.5 in addition		
Sine test according to DIN EN 60068-2-6:2008		10 cycles, 10...2000...10 Hz with logarithmic frequency changing speed of 1 oct./min., 5 to 57 Hz, amplitude 1.5 mm (p-p), 57 to 2000 Hz, amplitude 10 g, 3 axes		
Random test according to DIN EN 60068-2-64:2009		20...2000 Hz, amplitude 0.05 g ² /Hz (10 g _{RMS}) 3 axes, 30 min testing time per axis		
Shock test according to DIN EN 60068-2-27:2010		Half sine 15 g/11 ms, 3 times in positive/3 times in negative direction per axis, 3 axes		
Humid heat, cyclic according to DIN EN 60068-2-30:2006		Variant 2 +25 °C to +55 °C, 90% to 97% relative humidity, 2 cycles at 24 hours		

hydraulic

Size	Size	10	16	25
Operating pressure				
Pilot control valve WRZ(E) – External pilot oil supply – Internal pilot oil supply	bar	30 to 100		
	bar	100 to 315 only with "D3"	100 to 350 only with "D3"	
Control WRH – Ports X and Y	bar	25 maximum (cracking pressure approx. 5 bar)		
Main valve – Ports P, A, B	bar	Up to 315	Up to 350	Up to 350
Return flow pressure – Port T (external pilot oil return) – Port T (internal pilot oil return) – Port Y	bar	Up to 315	Up to 250	Up to 250
	bar	Up to 30	Up to 30	Up to 30
	bar	Up to 30	Up to 30	Up to 30
Flow of the main valve	l/min	Up to 170	Up to 460	Up to 870
Pilot flow at ports X and Y with stepped input signal 0 → 100%	l/min	3.5	5.5	7
Pilot volume for switching process 0 → 100%	cm ³	1.7	4.6	10
Hydraulic fluid		See table on page 8		
Hydraulic fluid temperature range	°C	-20 to +80 (preferably +40 to +50)		
Viscosity range	mm ² /s	20 to 380 (preferably 30 to 46)		
Maximum admissible degree of contamination of the hydraulic fluid, cleanliness class according to ISO 4406 (c) – Pilot control valve – Main valve		Class 18/16/13 ¹⁾		
		Class 20/18/15 ¹⁾		
Hysteresis	%	≤ 6		

¹⁾ The cleanliness classes specified for the components must be adhered to in hydraulic systems. Effective filtration prevents faults and at the same time increases the life cycle of the components.

For the selection of the filters see www.boschrexroth.com/filter

Technical data (for applications outside these parameters, please consult us!)

Hydraulic fluid	Classification	Suitable sealing materials	Standards
Mineral oils and related hydrocarbons	HL, HLP	NBR, FKM	DIN 51524
Flame-resistant – containing water	HFC (Fuchs HYDROTHERM 46M, Petrofer Ultra Safe 620)	NBR	ISO 12922
<p> Important information on hydraulic fluids!</p> <ul style="list-style-type: none"> – For more information and data on the use of other hydraulic fluids, refer to data sheet 90220 or contact us. – There may be limitations regarding the technical valve data (temperature, pressure range, life cycle, maintenance intervals, etc.)! – The flash point of the process and operating medium used must be 40 K greater than the maximum solenoid surface temperature. <ul style="list-style-type: none"> – Flame-resistant – containing water: The maximum pressure differential per control edge is 175 bar. Pressure pre-loading at the tank port >20% of the pressure differential; otherwise, increased cavitation. – Life cycle as compared to operation with mineral oil HL, HLP 50% to 100% 			

electric

Valve type		4WRZM ¹⁾	4WRZEM	
Voltage type		Direct voltage		
Command value overlap	%	20		
Maximum solenoid current	A	1.5	2.5	
Solenoid coil resistance	Cold value at 20 °C	Ω	4.8	2
	Maximum hot value	Ω	7.2	3
Duty cycle	%	100		
Maximum coil temperature ³⁾	°C	150		
Electrical connection		With connector according to DIN EN 175301-803 Mating connector according to DIN EN 175301-803 ²⁾ , see page 19	With connector according to DIN EN 175201-804 Mating connector according to DIN EN 175201-804 ²⁾ , see page 19	
Protection class of the valve according to EN 60529		IP65 with mating connectors mounted and locked		

¹⁾ With Rexroth control electronics

²⁾ Separate order

³⁾ Due to the temperatures occurring at the surfaces of the solenoid coils, the European standards ISO 13732-1 and DIN EN 982 need to be adhered to.

Technical data (for applications outside these parameters, please consult us!)

Control electronics

Integrated electronics (OBE) with type 4WRZEM		–	Integrated in the valve, see page 10
Current consumption	I_{\max}	A	1.8
	– Impulse current	A	3.0
Command value signal	– Voltage input "A1"	V	±10
	– Current input "F1"	mA	4 to 20
Suitable command value preparation for type WRZEM			
Analog command value card ¹⁾		VT-SWKA-1-1X/... according to data sheet RE 30255	
Digital command value card ¹⁾		VT-HACD-1-1X/... according to data sheet RE 30143	
Analog command value modules ¹⁾		VT-SWMA-1-1X/... according to data sheet RE 29902	
		VT-SWMAK-1-1X/... according to data sheet RE 29903	
External electronics for type 4WRZM			
Analog amplifier in Euro-card format ¹⁾	with 1 ramp time	VT- VSPA2-1-2X/V0/T1 according to data sheet RE 30110	
	with 5 ramp times	VT- VSPA2-1-2X/V0/T5 according to data sheet RE 30110	
Digital amplifier in Euro-card format ¹⁾		VT-VSPD-1-2X/... according to data sheet RE 30523	
Analog amplifier in modular design ¹⁾		VT 11118-1X/... according to data sheet RE 30218	

¹⁾ Separate order

electric, spool position indicator (see page 11)

Principle	Inductive position switch	
Switching point	Within positive valve overlap	
Supply voltage	VDC	24 ± 4.8
Residual ripple	< 10%	
Current consumption, without load current	mA	≤ 40
Reverse polarity protection	Installed, max. 300 V	
Outputs	Reverse polarity protected, positive switching and short-circuit-proof	
Protection class	IP 65 according to EN 60529 with installed connectors	
Duty cycle	100%	
Electrical connection	M12x1, 4-pole; assignment according to DIN EN 60947-5-2; mating connector, see page 19 (separate order)	

Electrical connection (dimensions in mm)

Type 4WRZM... for external electronics

For mating connectors, see page 19

Connector pin assignment

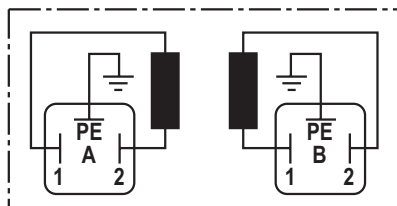

Mating connector pin assignment

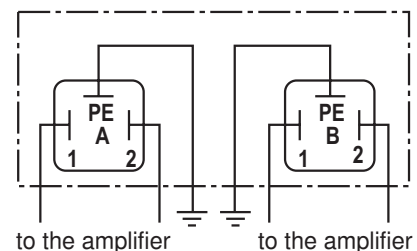

Electrical connection (dimensions in mm)

Type 4WRZEM..., with integrated electronics (OBE)

For mating connectors, see page 19

Connector pin assignment	Contact	Signal with A1	Signal at F1
Supply voltage	A	24 VDC ($u(t) = 19.4$ to 35 V); $I_{max} = 2$ A	
	B	0 V	
Reference (actual value)	C	Cannot be used ¹⁾	
Differential amplifier input (Command value)	D	± 10 V; $R_e > 50$ k Ω	4 to 20 mA; $R_e > 100$ Ω
	E	Command value reference potential	
	F	Cannot be used ¹⁾	
Protective grounding conductor	PE	Connected to cooling element and valve housing	

¹⁾ Contacts C and F must not be connected!

Mode of operation: A positive command value (0 to 10 V or 12 to 20 mA) at D and a reference potential at E result in a flow from P to A and B to T.
 A negative command value (0 to -10 V or 12 to 4 mA) at D and a reference potential at E result in a flow from P to B and A to T.
 If the valve and the solenoid are on side a (control spool variants **EA** and **W6A**), a reference potential at E and a positive command value at D (0 to 10 V or 4 to 20 mA) result in flow from P to B and A to T.

Block diagram of the integrated electronics

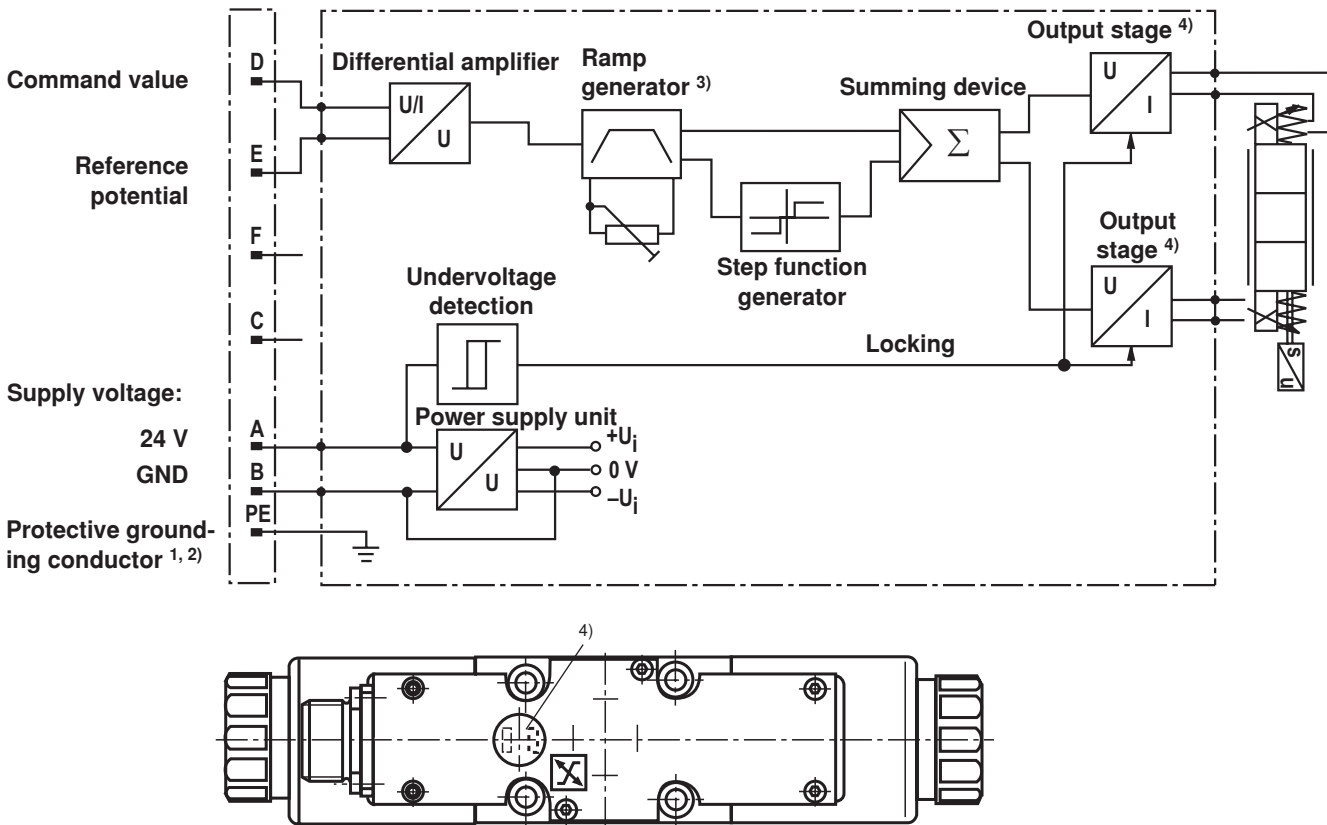

- 1) Port PE is connected to the cooling element and the valve housing
- 2) The protective grounding conductor is connected to the valve housing and cover
- 3) Ramp can be set from 0 to 2.5 s from the outside, identical for T_{up} and T_{down}
- 4) The output stages are current-controlled

Electrical connection (dimensions in mm)

Type 4WRZM... , 4WRZEM..., spool position indicator

Connector pin assignment

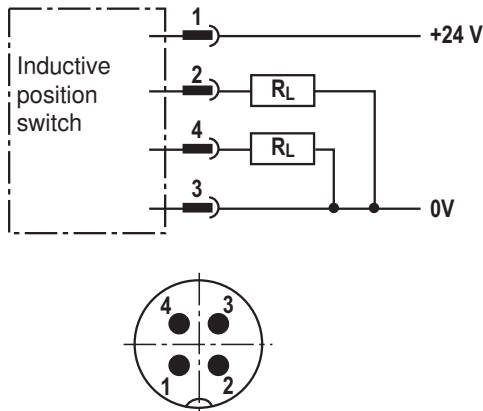

	Pin	Signal	Mating connector wire color
Supply voltage	1	$U_B = +24\text{ V} \pm 4.8\text{ V}$	Brown
Switching output 1	2	Switching status 0 (open): $< 1.8\text{ VDC}$ Switching status 1 (closed): $> U_B - 2.5\text{ V}$ (Limit load $I_{\text{max}} = 250\text{ mA}$)	White
Weight	3	0 V	Blue
Switching output 2	4	Switching status 0 (open): $< 1.8\text{ V DC}$ Switching status 1 (closed): $> U_B - 2.5\text{ V}$ (Limit load $I_{\text{max}} = 250\text{ mA}$)	Black

Notice: The position switch has no ground contact. Therefore, the use of protective extra-low voltage sources according to PELV (IEC64) is mandatory.

Switching logic

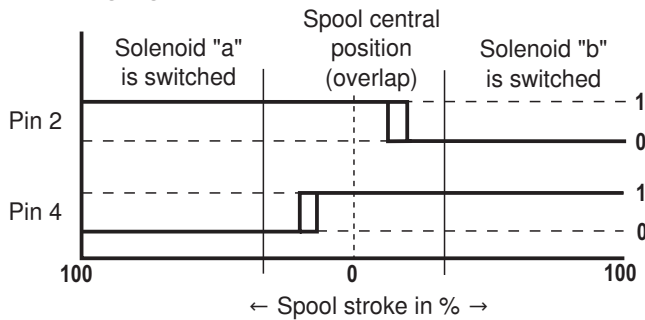

Characteristic curves size 10 (control spool "E, W6-, EA, W6A" as well as HLP46, $\vartheta_{oil} = 40 \text{ }^\circ\text{C} \pm 5 \text{ }^\circ\text{C}$ and $p = 100 \text{ bar}$)

25 l/min rated flow at 10 bar valve pressure differential

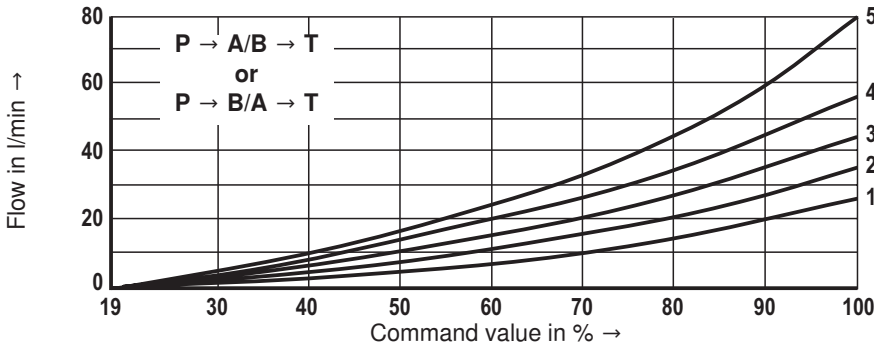

- 1 $\Delta p = 10 \text{ bar, constant}$
- 2 $\Delta p = 20 \text{ bar, constant}$
- 3 $\Delta p = 30 \text{ bar, constant}$
- 4 $\Delta p = 50 \text{ bar, constant}$
- 5 $\Delta p = 100 \text{ bar, constant}$

50 l/min rated flow at 10 bar valve pressure differential

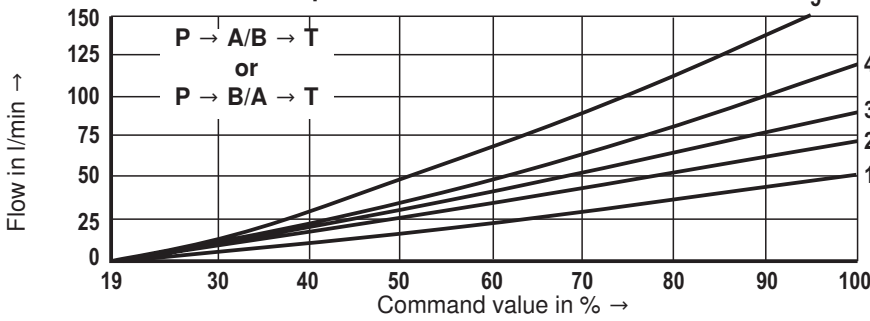

- 1 $\Delta p = 10 \text{ bar, constant}$
- 2 $\Delta p = 20 \text{ bar, constant}$
- 3 $\Delta p = 30 \text{ bar, constant}$
- 4 $\Delta p = 50 \text{ bar, constant}$
- 5 $\Delta p = 100 \text{ bar, constant}$

85 l/min rated flow at 10 bar valve pressure differential

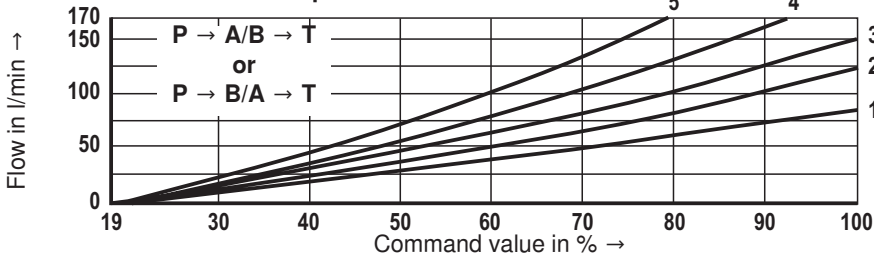

- 1 $\Delta p = 10 \text{ bar, constant}$
- 2 $\Delta p = 20 \text{ bar, constant}$
- 3 $\Delta p = 30 \text{ bar, constant}$
- 4 $\Delta p = 50 \text{ bar, constant}$
- 5 $\Delta p = 100 \text{ bar, constant}$

$\Delta p =$ valve pressure differential according to DIN 24311 (inlet pressure p_p minus load pressure p_L minus return flow pressure p_T)

Transition functions with stepped, electric input signals, measured at $p_{St} = 50 \text{ bar}$

Type 4WRZM...

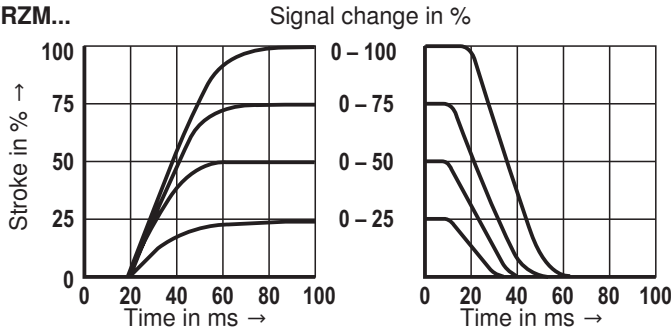

Type 4WRZEM...

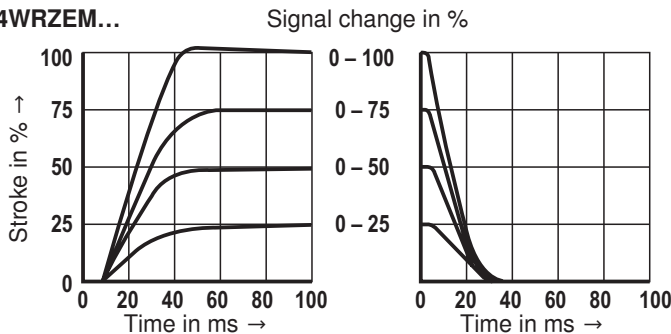

Characteristic curves size 16 (control spool "E, W6-, EA, W6A" as well as HLP46, $\vartheta_{oil} = 40 \text{ }^\circ\text{C} \pm 5 \text{ }^\circ\text{C}$ and $p = 100 \text{ bar}$)

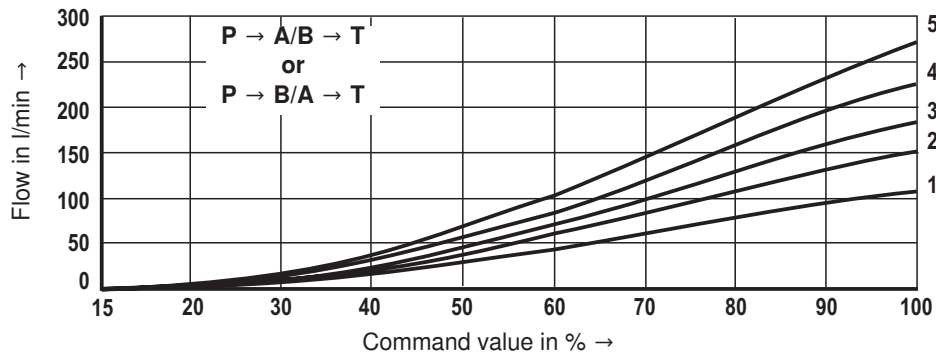
100 l/min rated flow at 10 bar valve pressure differential

- 1 $\Delta p = 10 \text{ bar}$, constant
- 2 $\Delta p = 20 \text{ bar}$, constant
- 3 $\Delta p = 30 \text{ bar}$, constant
- 4 $\Delta p = 50 \text{ bar}$, constant
- 5 $\Delta p = 100 \text{ bar}$, constant

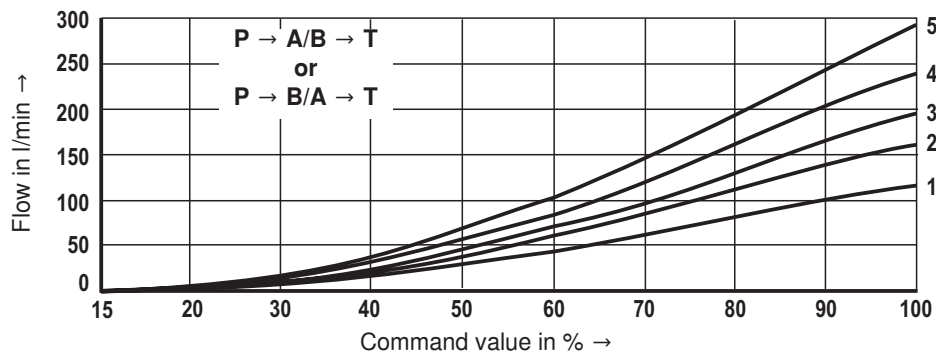
125 l/min rated flow at 10 bar valve pressure differential

- 1 $\Delta p = 10 \text{ bar}$, constant
- 2 $\Delta p = 20 \text{ bar}$, constant
- 3 $\Delta p = 30 \text{ bar}$, constant
- 4 $\Delta p = 50 \text{ bar}$, constant
- 5 $\Delta p = 100 \text{ bar}$, constant

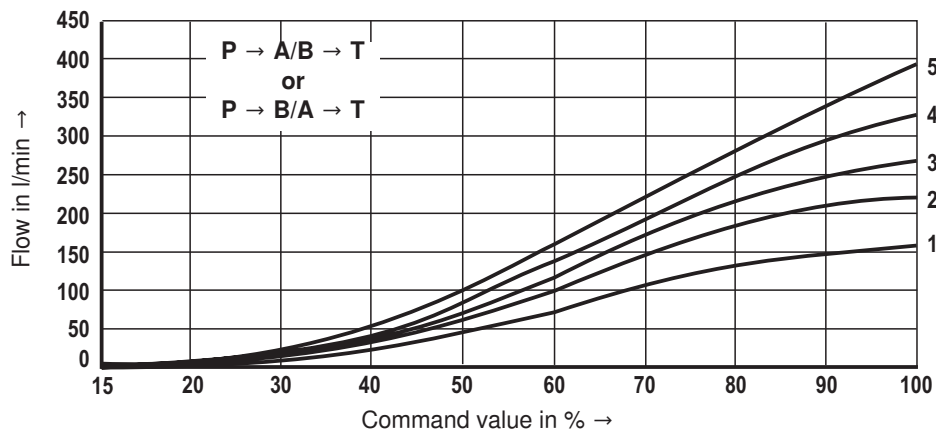
150 l/min rated flow at 10 bar valve pressure differential

- 1 $\Delta p = 10 \text{ bar}$, constant
- 2 $\Delta p = 20 \text{ bar}$, constant
- 3 $\Delta p = 30 \text{ bar}$, constant
- 4 $\Delta p = 50 \text{ bar}$, constant
- 5 $\Delta p = 100 \text{ bar}$, constant

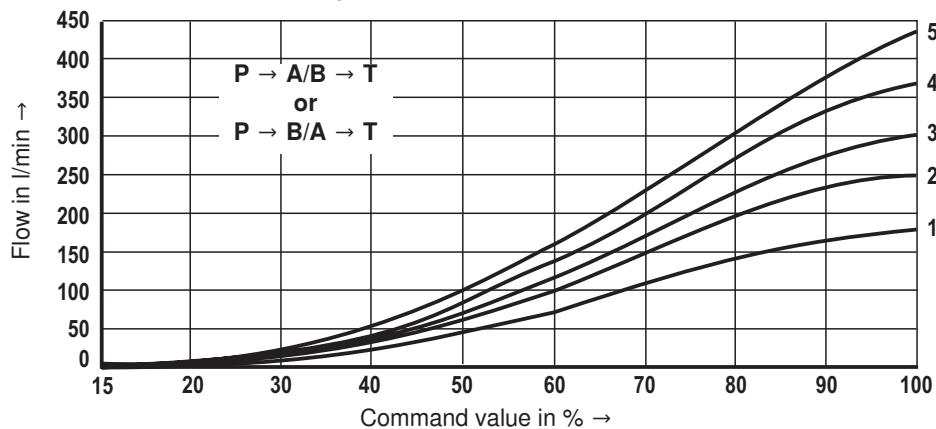
180 l/min rated flow at 10 bar valve pressure differential

- 1 $\Delta p = 10 \text{ bar}$, constant
- 2 $\Delta p = 20 \text{ bar}$, constant
- 3 $\Delta p = 30 \text{ bar}$, constant
- 4 $\Delta p = 50 \text{ bar}$, constant
- 5 $\Delta p = 100 \text{ bar}$, constant

Δp = valve pressure differential according to DIN 24311 (inlet pressure p_p minus load pressure p_L minus return flow pressure p_T)

Characteristic curves size 16 (control spool "E, W6-, EA, W6A" as well as HLP46, $\vartheta_{oil} = 40 \text{ }^\circ\text{C} \pm 5 \text{ }^\circ\text{C}$ and $p = 100 \text{ bar}$)

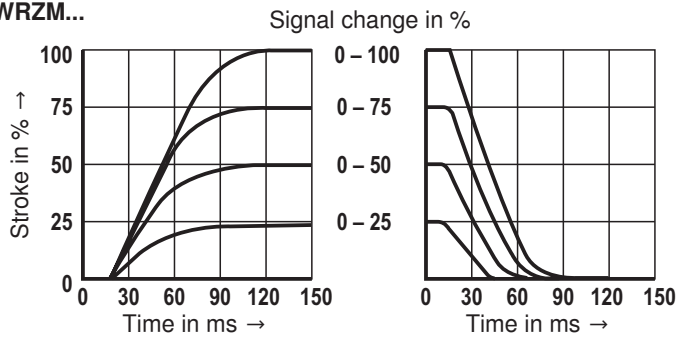
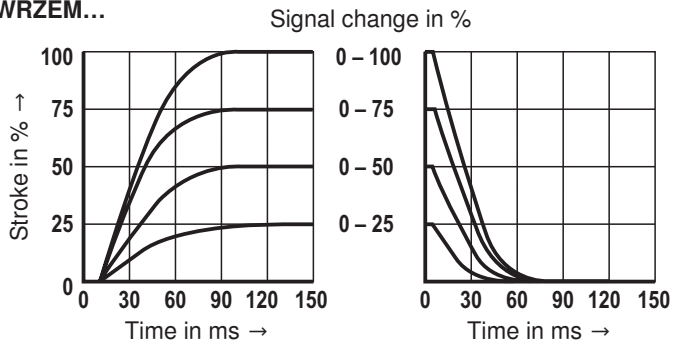
Transition functions with stepped, electric input signals, measured at $p_{St} = 50 \text{ bar}$
Type 4WRZM...

Type 4WRZEM...

Characteristic curves size 25 (control spools "E, W6-, EA, W6A" as well as HLP46, $\vartheta_{oil} = 40 \text{ }^\circ\text{C} \pm 5 \text{ }^\circ\text{C}$ and $p = 100 \text{ bar}$)

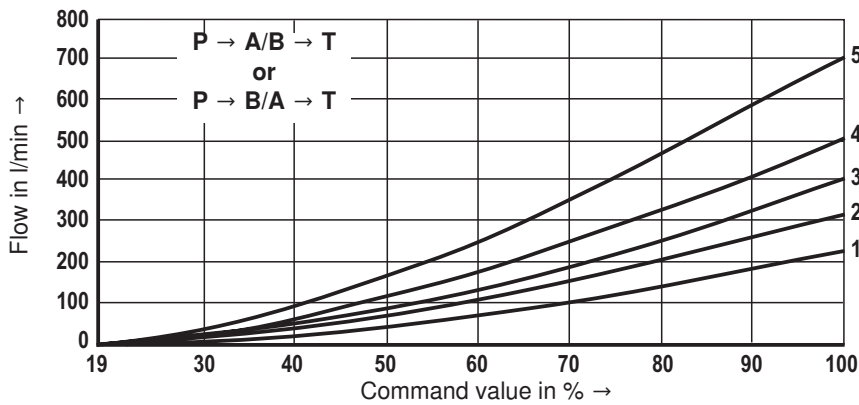
220 l/min rated flow at 10 bar valve pressure differential



- 1 $\Delta p = 10 \text{ bar, constant}$
- 2 $\Delta p = 20 \text{ bar, constant}$
- 3 $\Delta p = 30 \text{ bar, constant}$
- 4 $\Delta p = 50 \text{ bar, constant}$
- 5 $\Delta p = 100 \text{ bar, constant}$

325 l/min rated flow at 10 bar valve pressure differential

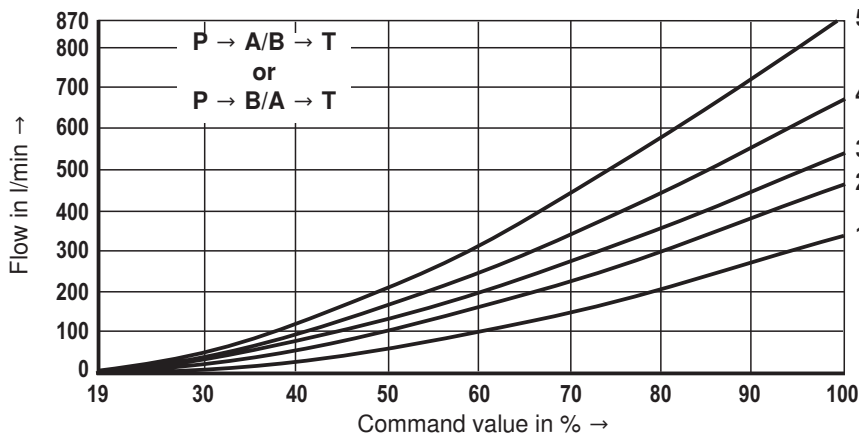

- 1 $\Delta p = 10 \text{ bar, constant}$
- 2 $\Delta p = 20 \text{ bar, constant}$
- 3 $\Delta p = 30 \text{ bar, constant}$
- 4 $\Delta p = 50 \text{ bar, constant}$
- 5 $\Delta p = 100 \text{ bar, constant}$

Δp = valve pressure differential according to DIN 24311 (inlet pressure p_p minus load pressure p_L minus return flow pressure p_T)

Transition functions with stepped, electric input signals, measured at $p_{St} = 50 \text{ bar}$

Type 4WRZM...

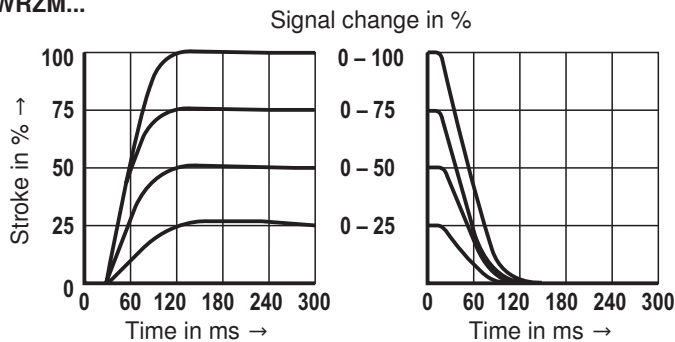

Type 4WRZEM...

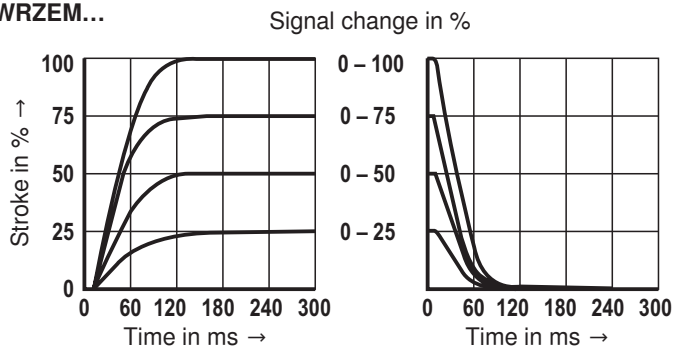

Dimensions: Size 10 (dimensions in mm)

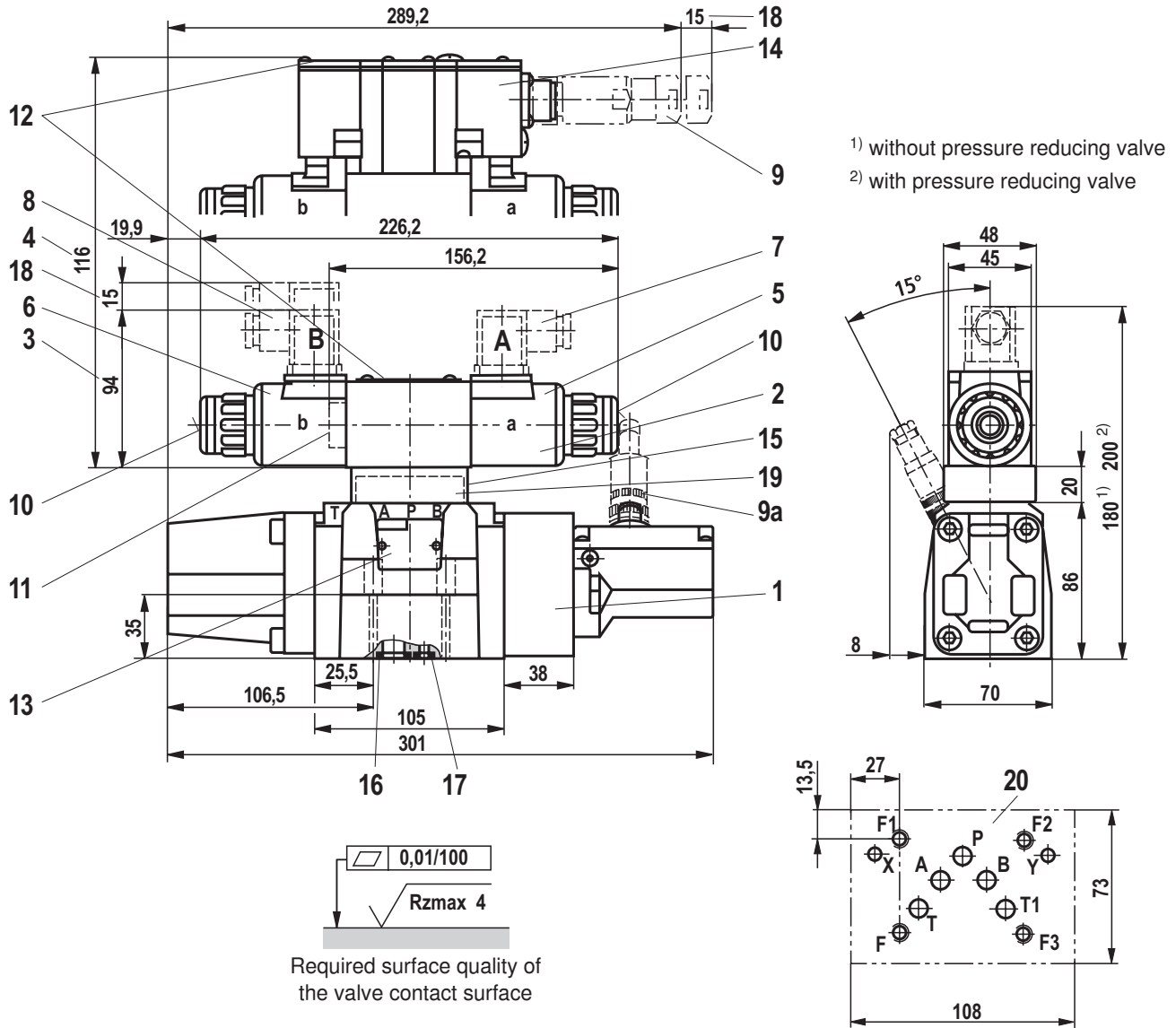

1) without pressure reducing valve
2) with pressure reducing valve

- 1 Main valve
- 2 Pilot control valve
- 3 Dimension for version "4WRZM..."
- 4 Dimension for version "4WRZEM..."
- 5 Proportional solenoid "a"
- 6 Proportional solenoid "b"
- 7 Mating connector "A", separate order, see page 19
- 8 Mating connector "B", separate order, see page 19
- 9 Mating connector, separate order, see page 19
- 9a Mating connector, separate order, see page 19
- 10 Concealed manual override "N9"
- 11 Plug screw for valves with one solenoid
- 12 Name plate for pilot control valve
- 13 Name plate for main valve
- 14 Integrated electronics (OBE)
- 15 Pressure reducing valve "D3"
- 16 Identical seal rings for ports A, B, P, T, and T1
- 17 Identical seal rings for ports X and Y
- 18 Space required for removing the mating connector
- 19 Diversion plate (type 4WRHM...)
- 20 Machined installation surface, porting pattern according to ISO 4401-05-05-0-05, ports X and Y as required

For subplates and valve mounting screws, see page 19

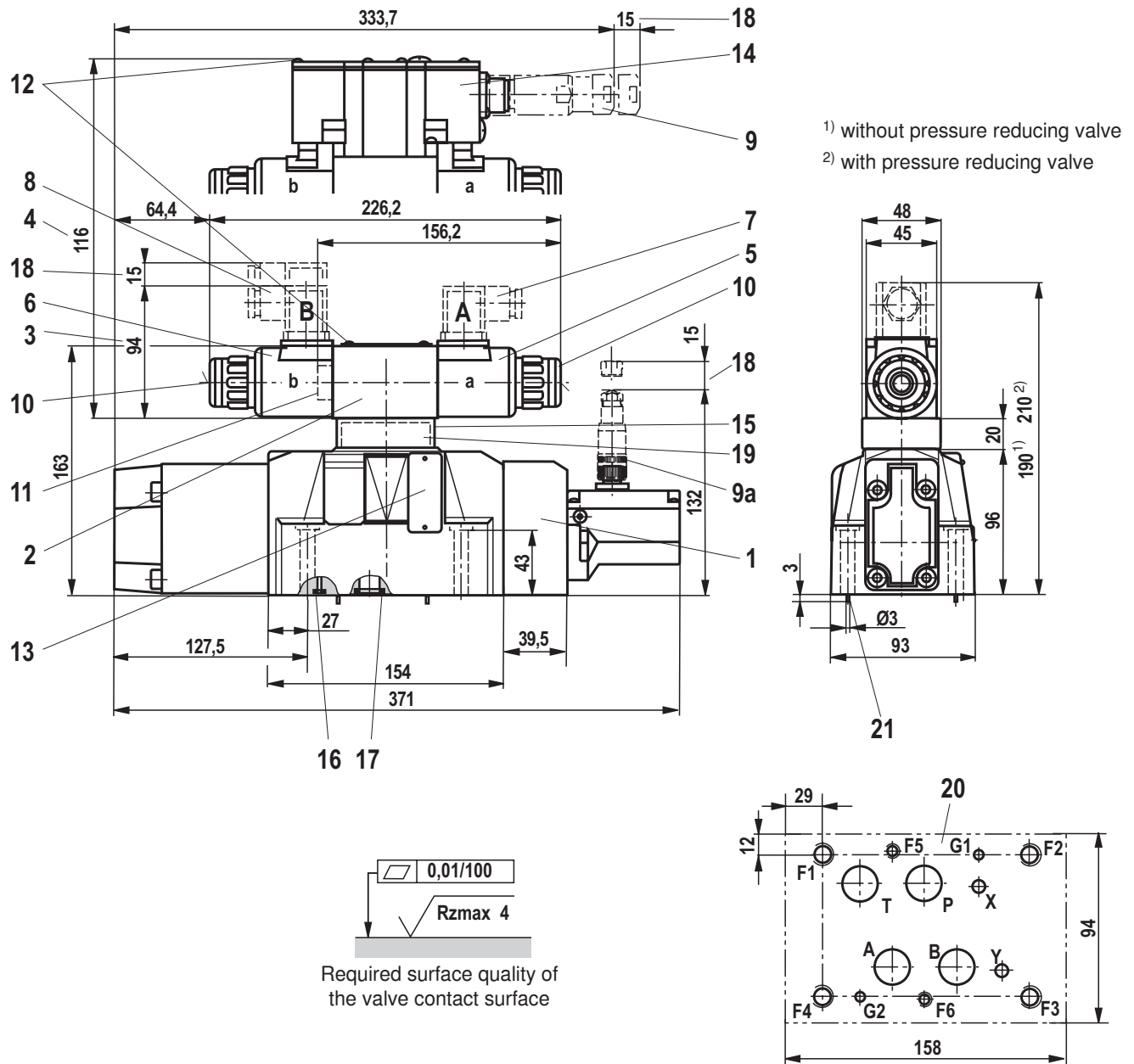
Dimensions: Size 16 (dimensions in mm)

- | | |
|---|--|
| <ul style="list-style-type: none"> 1 Main valve 2 Pilot control valve 3 Dimension for version "4WRZM..." 4 Dimension for version "4WRZEM..." 5 Proportional solenoid "a" 6 Proportional solenoid "b" 7 Mating connector "A", separate order, see page 19 8 Mating connector "B", separate order, see page 19 9 Mating connector, separate order, see page 19 9a Mating connector, separate order, see page 19 10 Concealed manual override "N9" 11 Plug screw for valves with one solenoid 12 Name plate for pilot control valve | <ul style="list-style-type: none"> 13 Name plate for main valve 14 Integrated electronics (OBE) 15 Pressure reducing valve "D3" 16 Identical seal rings for ports A, B, P, and T 17 Identical seal rings for ports X and Y 18 Space required for removing the mating connector 19 Diversion plate (type 4WRHM...) 20 Machined installation surface, porting pattern according to ISO 4401-07-07-0-05, ports X and Y as required
Deviating from the standard: Ports A, B, P, and T = Ø20 mm 21 Locking pin |
|---|--|

For subplates and valve mounting screws, see page 19

Dimensions: Size 25 (dimensions in mm)

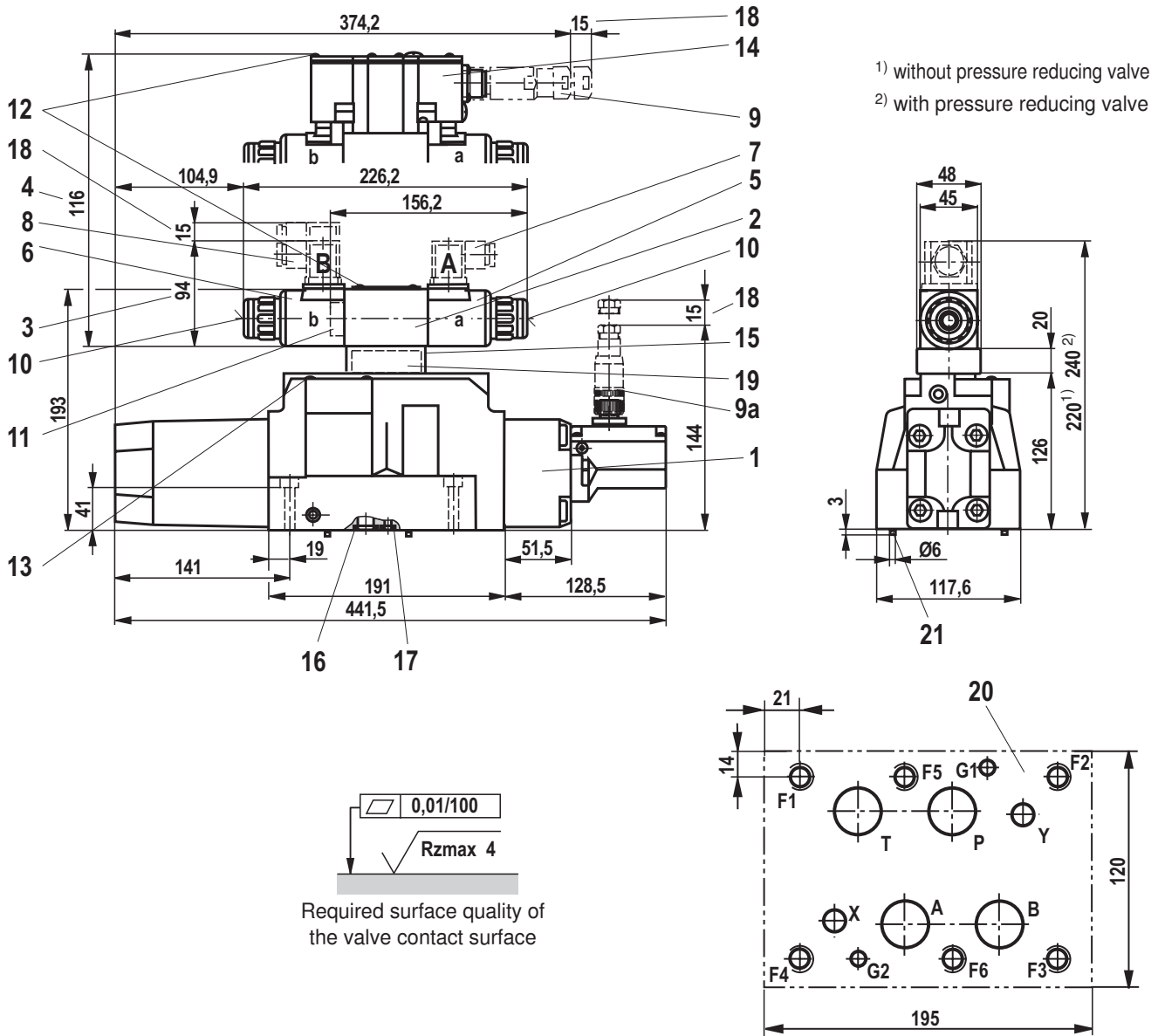

- 1 Main valve
- 2 Pilot control valve
- 3 Dimension for version "4WRZM..."
- 4 Dimension for version "4WRZEM..."
- 5 Proportional solenoid "a"
- 6 Proportional solenoid "b"
- 7 Mating connector "A", separate order, see page 19
- 8 Mating connector "B", separate order, see page 19
- 9 Mating connector, separate order, see page 19
- 9a Mating connector, separate order, see page 19
- 10 Concealed manual override "N9"
- 11 Plug screw for valves with one solenoid
- 12 Name plate for pilot control valve
- 13 Name plate for main valve
- 14 Integrated electronics (OBE)
- 15 Pressure reducing valve "D3"
- 16 Identical seal rings for ports A, B, P, and T
- 17 Identical seal rings for ports X and Y
- 18 Space required for removing the mating connector
- 19 Diversion plate (type 4WRHM...)
- 20 Machined installation surface, porting pattern according to ISO 4401-08-08-0-05
- 21 Locking pin

For subplates and valve mounting screws, see page 19

Dimensions

Hexagon socket head cap screws		Material number
Size 10	4x ISO 4762 - M6 x 45 - 10.9-flZn-240h-L Tightening torque $M_A = 13.5 \text{ Nm} \pm 10\%$ or 4x ISO 4762 - M6 x 45 - 10.9 Tightening torque $M_A = 15.5 \text{ Nm} \pm 10\%$	R913000258
Size 16	2x ISO 4762 - M6 x 60 - 10.9-flZn-240h-L Tightening torque $M_A = 12.2 \text{ Nm} \pm 10\%$	R913000115
	4x ISO 4762 - M10 x 60 - 10.9-flZn-240h-L Tightening torque $M_A = 58 \text{ Nm} \pm 20\%$ or 2x ISO 4762 - M6 x 60 - 10.9 Tightening torque $M_A = 15.5 \text{ Nm} \pm 10\%$ 4x ISO 4762 - M10 x 60 - 10.9 Tightening torque $M_A = 75 \text{ Nm} \pm 20\%$	R913000116
Size 25	6x ISO 4762 - M12 x 60 - 10.9-flZn-240h-L Tightening torque $M_A = 100 \text{ Nm} \pm 20\%$ or 6x ISO 4762 - M12 x 60 - 10.9 Tightening torque $M_A = 130 \text{ Nm} \pm 20\%$	R913000121

Notice: The tightening torque of the hexagon socket head cap screws refers to maximum operating pressure.

Subplates	Data sheet
Size 10	45054
Size 16	45056
Size 25	45058

Accessories (not included in the scope of delivery)

Mating connectors		Material number
Mating connector for 4WRZM	DIN EN 175201-803, see data sheet 08006	Solenoid a, gray, R901017010
		Solenoid b, black, R901017011
Mating connector for 4WRZEM	DIN EN 175201-804, see data sheet 08006	e.g. R900021267 (plastic)
		e.g. R900223890 (metal)
Mating connector for spool position indicator	IEC 60947-5-2, see data sheet 08006	e.g. R900031155 (M12x1 with screw connection)
		e.g. R900082899 (M12x1 with screw connection, angled, rotatable 4x90°)

Safety instructions

Instructions on project planning, installation and commissioning

- When implementing safety-related controls comply with the applicable industry-specific standards and regulations.
- Due to the flexible use of valves in systems, the user has to check and ensure that the product characteristics comply with all functional and safety requirements of the overall system.
- Make sure that there are no switching shocks and that the valve spool does not vibrate.
- Valves with spool position indicators may only be installed, adjusted, commissioned and maintained by specialists trained in hydraulics and electronics.
Improper work at safety-related parts of controls may result in personal injury and damage to property!

The following applies to all work carried out at the valve:

- Valves with spool position indicators must not be disassembled.
- Parts of the valves must not be exchanged.
- Integrated throttles must not be removed or modified.
- The spool position indicator may only be adjusted by the valve manufacturer.