

Characteristics / Ordering Code

Cartridge manifold blocks are bodies for 2/2-way slip-in cartridge valves. They are used in systems with only one cartridge valve without the need to design a specific manifold block.

The pilot ports X and Y can either be connected to A and B or vice versa by changing the mounting position of the cartridge cover.

The wide range of Parker slip-in cartridge valves allows to design solutions for all hydraulic requirements.

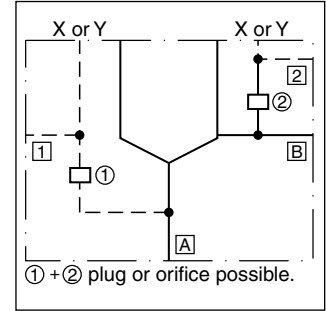
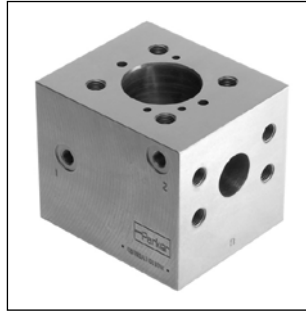

Features

- Flanges SAE62 respectively CETOP square flange
- 2 options for pilot oil supply and drain
- 6 sizes

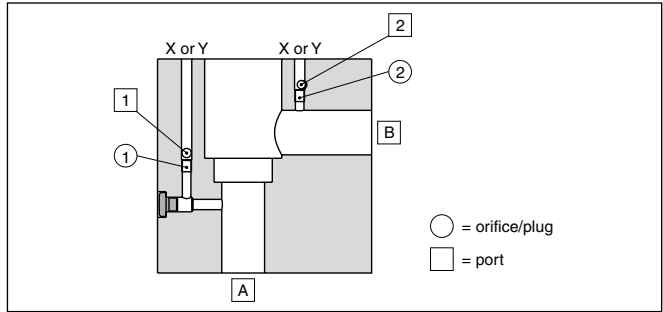

Ordering code

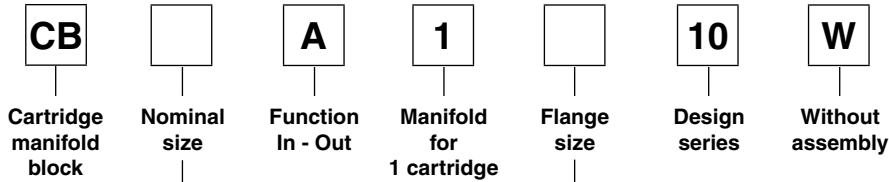

Code	Size
016	NG16
025	NG25
032	NG32
040	NG40
050	NG50
063	NG63

Code	Size	Flange
64	016	1" SAE62
65	025	1 ¼" SAE62
66	032	1 ½" SAE62
68	040/050	2" SAE62
70	063	3 ½" PN400

Technical data

Mounting interface	ISO 7368-B*-2-A/B
Mounting position	unrestricted
Max. operating pressure [bar]	up to 420 (depending on p _{max} of flanges)
Flanges	SAE62 (6000 PSI series) ISO 6162, CETOP-square flange (400 bar series)
Surface protection	phosphated

Dimensions

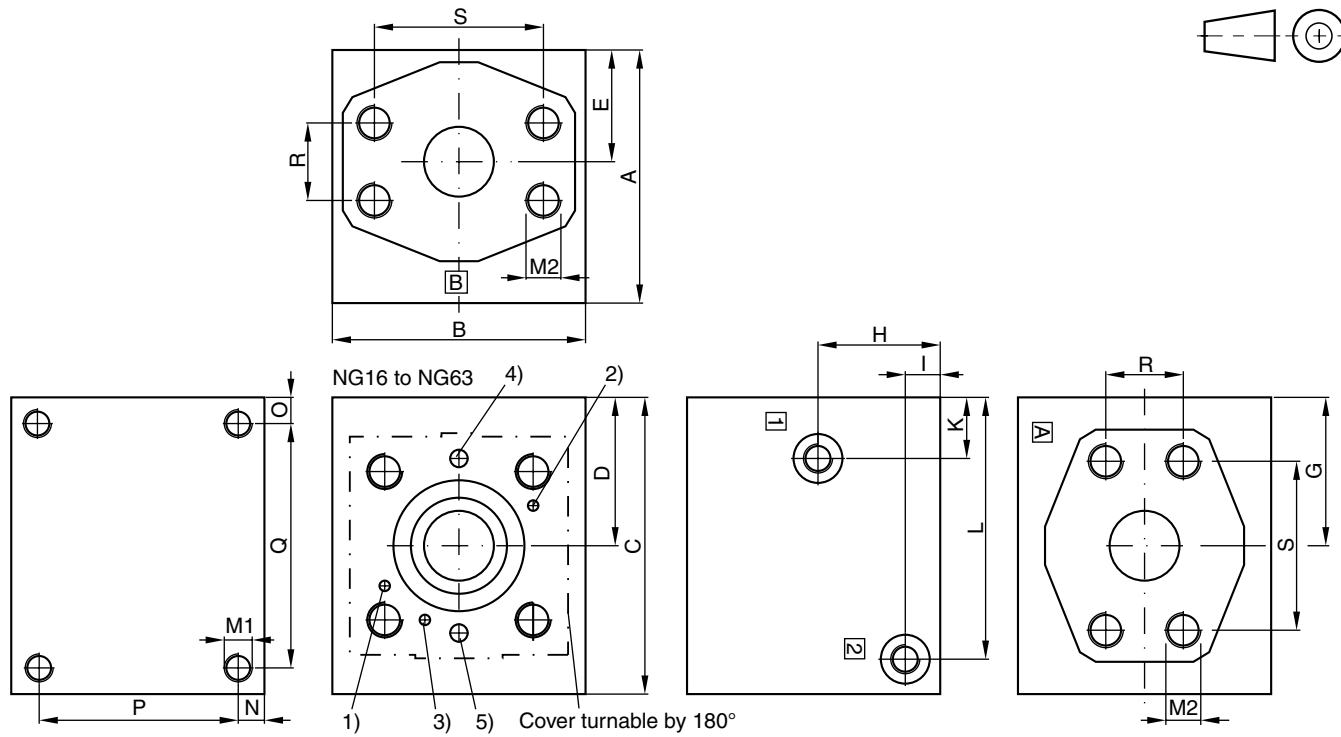
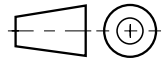

- 1) Location pin for X connected to **B** and **2**, Y connected to **A** and **1**
- 2) Location pin for X connected to **A** and **1**, Y connected to **B** and **2**
- 3) Location pin for pressure functions
- 4) X or Y, orifice/plug ① (connected to **A** and **1**)
- 5) X or Y, orifice/plug ② (connected to **B** and **2**)

Ordering code	Max. operating pressure [bar]	A	B	C	D	E	G	H	I	K	L	N	O	P	Q	Port A and B	Port 1 and 2	Orifice thread 1 and 2	Weight [kg]
CB 016 A 1 64 10 W	420	105	80	105	38.5	34	38.5	45	13	13.5	75.5	10	10	85	85	1" SAE62	G1/4	M5	6
CB 025 A 1 65 10 W	420	125	100	125	50	43	50	55	15	17	94.5	10	10	105	105	1-1/4" SAE62	G1/4	M6	11
CB 032 A 1 66 10 W	420	125	125	145	72.5	51	72.5	55	15	31.5	125	15	15	95	115	1-1/2" SAE62	G1/4	M6	16
CB 040 A 1 68 10 W	420	145	145	170	85	65	85	70	20	35	150	15	15	115	140	2" SAE62	G3/8	M8	25
CB 050 A 1 68 10 W	420	155	155	190	95	70	95	70	20	37	170	15	15	125	160	2" SAE62	G3/8	M8	32
CB 063 A 1 70 10 W	400	192	192	240	120	86.5	120	86.5	20	45	220	15	15	162	210	3-1/2" PN 400	G3/8	M8	63

Ordering code	M1	M2	R	S
CB 016 A 1 64 10 W	M8 x 16	M12x19	27.8	57.2
CB 025 A 1 65 10 W	M10 x 18	M14x22	31.8	66.6
CB 032 A 1 66 10 W	M16 x 30	M16x32	36.5	79.3
CB 040 A 1 68 10 W	M16 x 30	M20x40	44.5	96.8
CB 050 A 1 68 10 W	M16 x 30	M20x40	44.5	96.8
CB 063 A 1 70 10 W	M16 x 30	M20x33	102.5	102.5

Cartridge manifold blocks are supplied with a set of plugs and orifices.