

**Characteristics / Ordering Code**

Check valves from the Parker Manapak series CM are in sandwich design for easy configuration of stack systems. Depending on the function required, one or two check valves are arranged in ports P, T, A, and B. Number and flow direction can be selected from the ordering code.

**Features**

- The valve bodies of the Parker Manapak valve series CM are made of steel.
- Eight options for the arrangement of the check valve in the body offer a multitude of uses for hydraulic switching.
- The function can be changed by turning the valve.
- CM2 - NG06 (CETOP 03)
- CM3 - NG10 (CETOP 05)

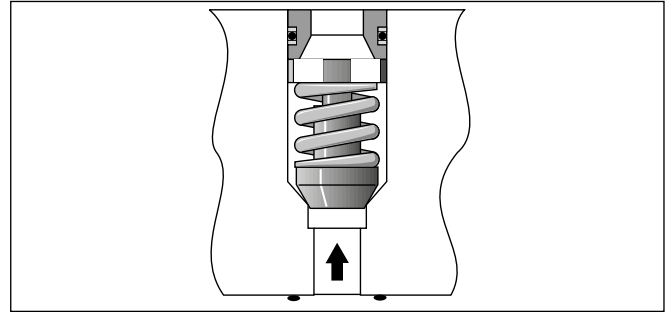
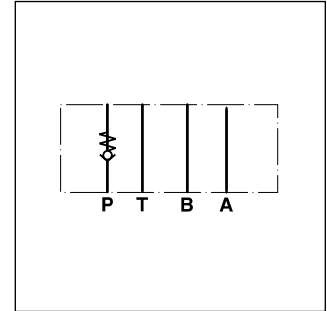

**Ordering code**

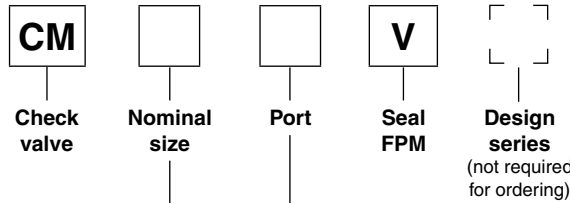

Code	Nominal size
2	<b>Intermediate plate DIN NG06</b>
3	<b>Intermediate plate DIN NG10</b>

Code	Free flow polarity	Check valve in channel
<b>AA</b>	<b>From directional valve to manifold</b>	<b>A</b>
<b>BB</b>	<b>From directional valve to manifold</b>	<b>B</b>
<b>DD</b>	<b>From directional valve to manifold</b>	<b>A and B</b>
<b>PP</b>	<b>From manifold to directional valve</b>	<b>P</b>
<b>TT</b>	<b>From directional valve to manifold</b>	<b>T</b>
AAF	From manifold to directional valve	A
BBF	From manifold to directional valve	B
DDF	From manifold to directional valve	A and B

**Bold letters = Short-term availability**

Technical Data / Performance Curves

Technical data

General			
Series		<b>CM2</b>	<b>CM3</b>
Size		<b>NG06</b>	<b>NG10</b>
Mounting interface		DIN 24340 A6 ISO 4401 NFPA D03	DIN 24340 A10 ISO 4401 NFPA D05
Mounting position		unrestricted	
Ambient temperature	[°C]	-20...+60	
MTTF <sub>D</sub> value	[years]	150	
Weight	[kg]	0.9	1.7
Hydraulic			
Max. operating pressure	[bar]	350	350
Max. flow	[l/min]	53	76
Opening pressure	[bar]	0.3	0.3
Fluid		Hydraulic oil according to DIN 51524	
Fluid temperature	[°C]	-20...+70	
Viscosity, permitted	[cSt] / [mm <sup>2</sup> /s]	20...400	
Viscosity, recommended	[cSt] / [mm <sup>2</sup> /s]	30...80	
Filtration		ISO 4406 (1999); 18/16/13	

Schematics

The valve side is shown at the top of the symbols, the manifold side with channel designation is shown at the bottom.

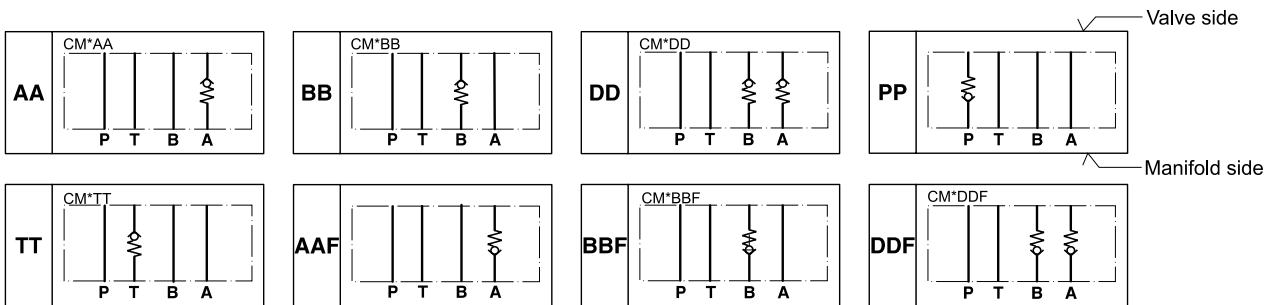

Δp/Q performance curves

CM2

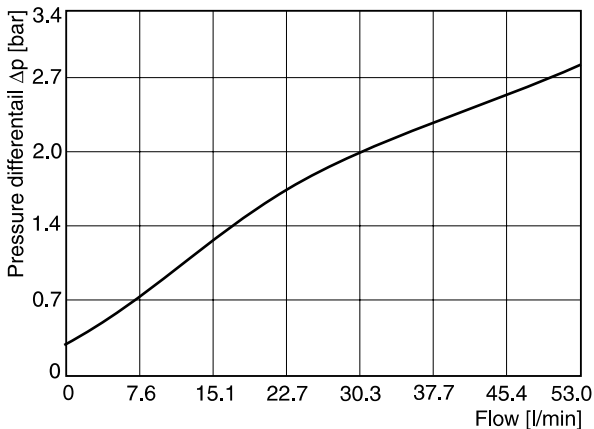

CM3

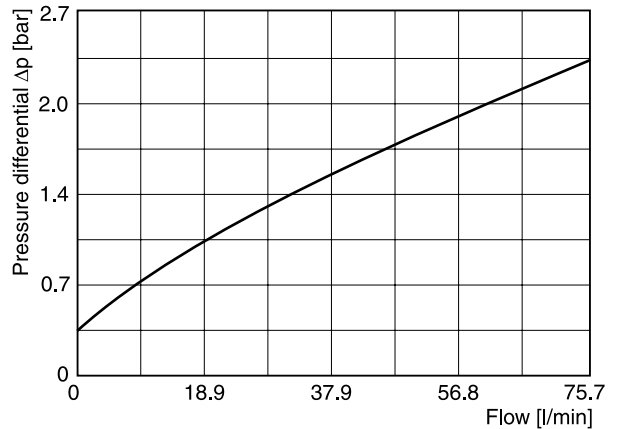

All characteristic curves measured with HLP46 at 50 °C.

**Dimensions**

**CM2**

**Bottom view<sup>1)</sup>**

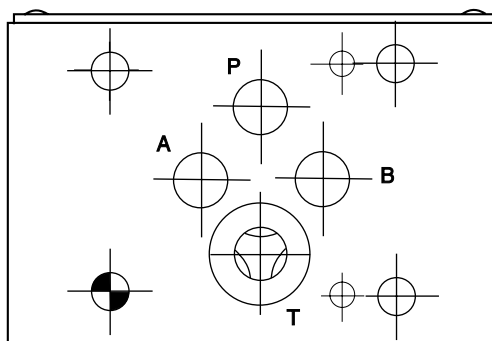

**Front side**

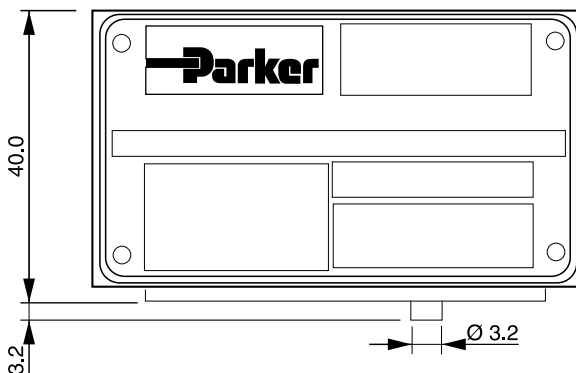

**Top view**

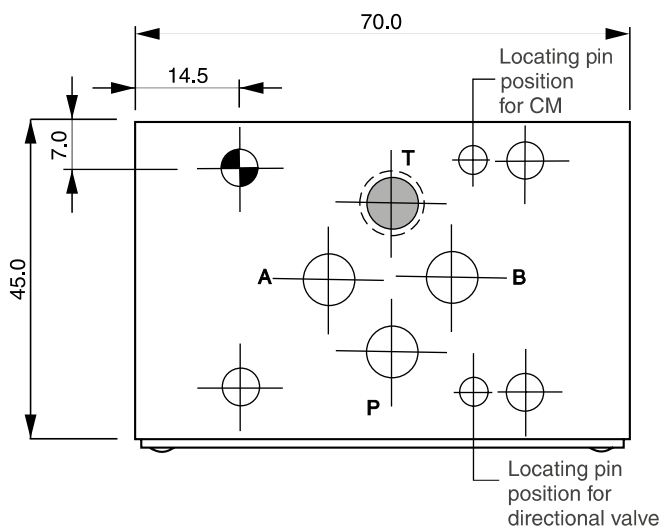

Seal kit CM2	
Seal	Order code
V	SK-CM2-V

**Note:**

The O-ring plate for sealing the connecting surface of the manifold side is included. The O-ring plate and the positioning pin are always mounted on the manifold side.

<sup>1)</sup> O-Ring plate is not shown! This view shows the TT model.

**CM2 top views (from directional valve side)**

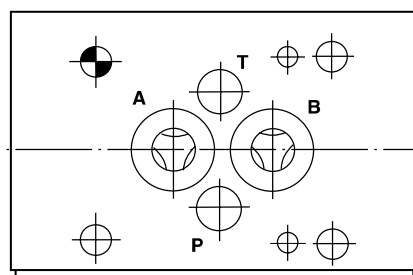
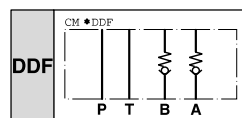
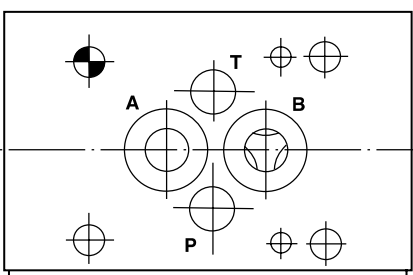
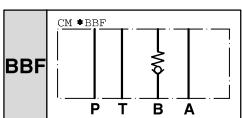
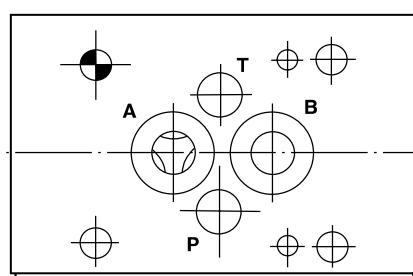
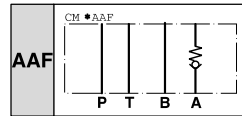
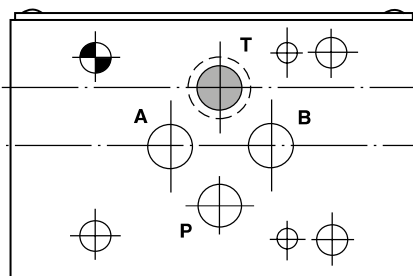
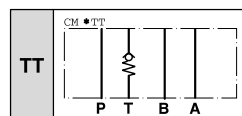
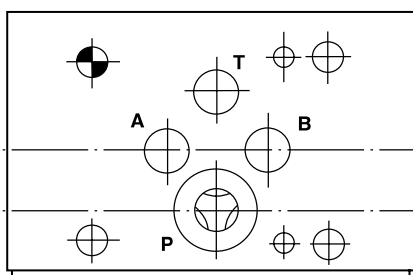
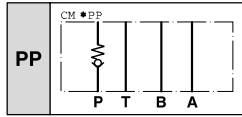
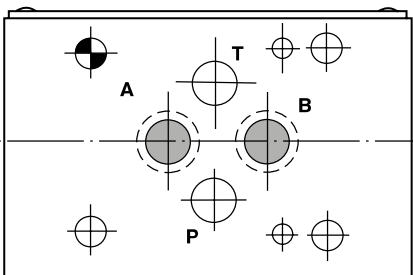
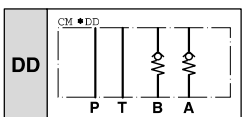
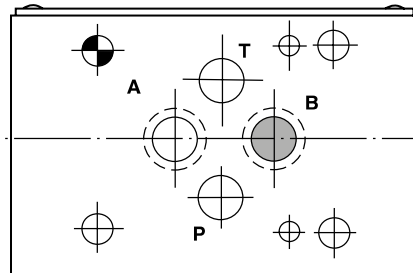
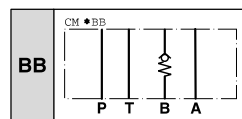
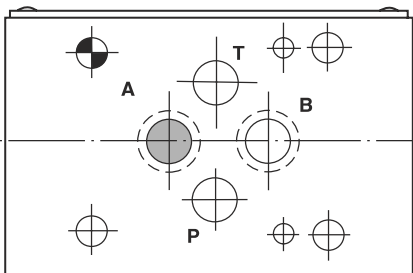
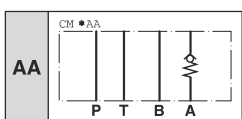

7

**Dimensions**

**CM3**

**Bottom view<sup>1)</sup>**

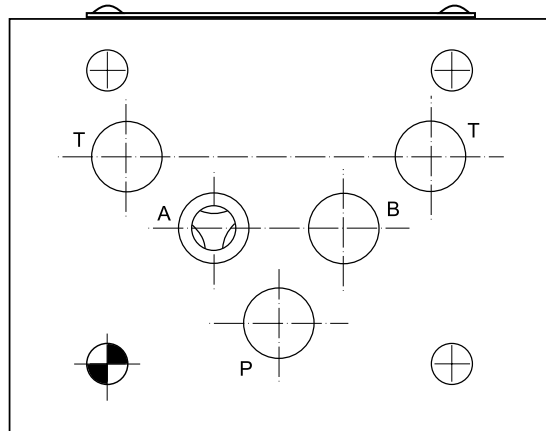

**Front side**

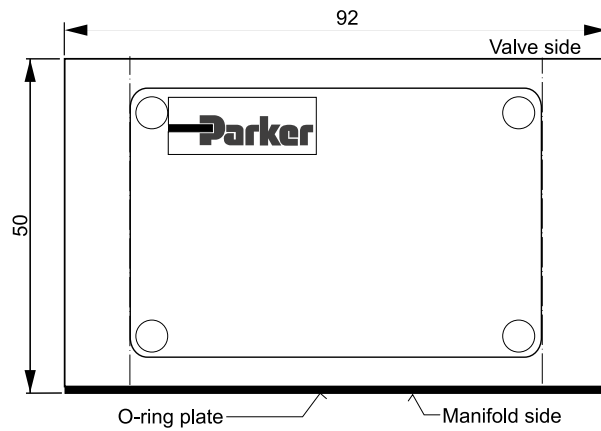

**Top view**

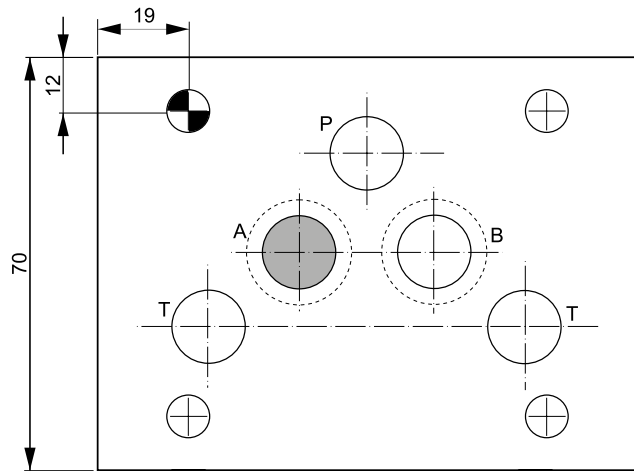

Seal kit CM3	
Seal	Order code
V	SK-CM3-V

**Note:**

The O-ring plate for sealing the connecting surface of the manifold side is included. The O-ring plate and the positioning pin are always mounted on the manifold side.

<sup>1)</sup> O-ring plate is not shown! This view shows the AA model.

**CM3 top views (from directional valve side)**

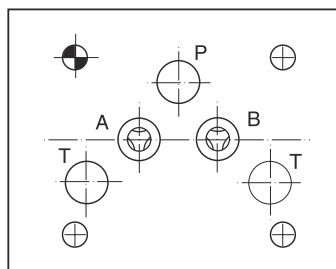
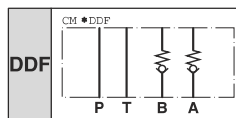
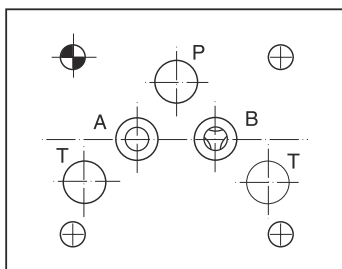
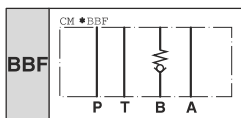
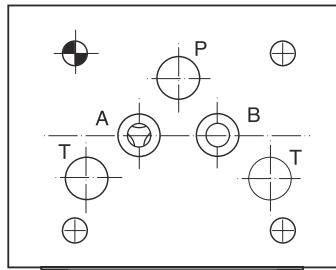
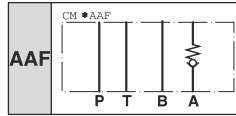
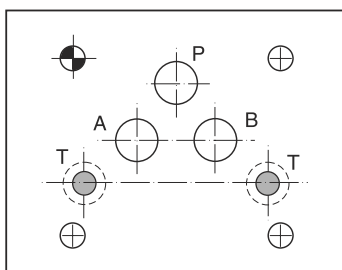
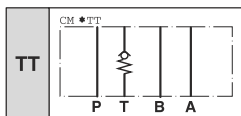
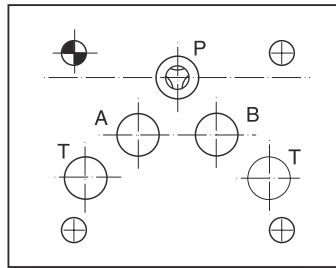
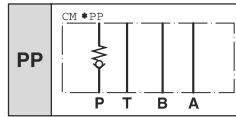
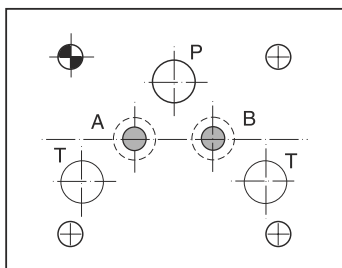
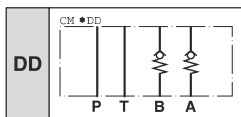
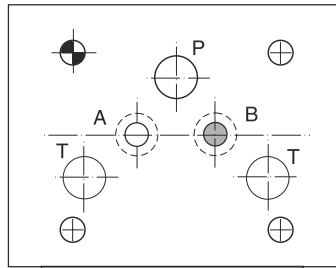
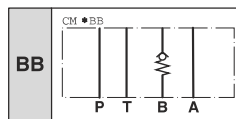
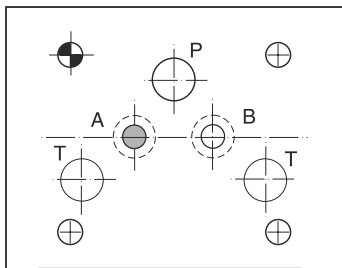
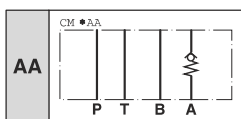

7